

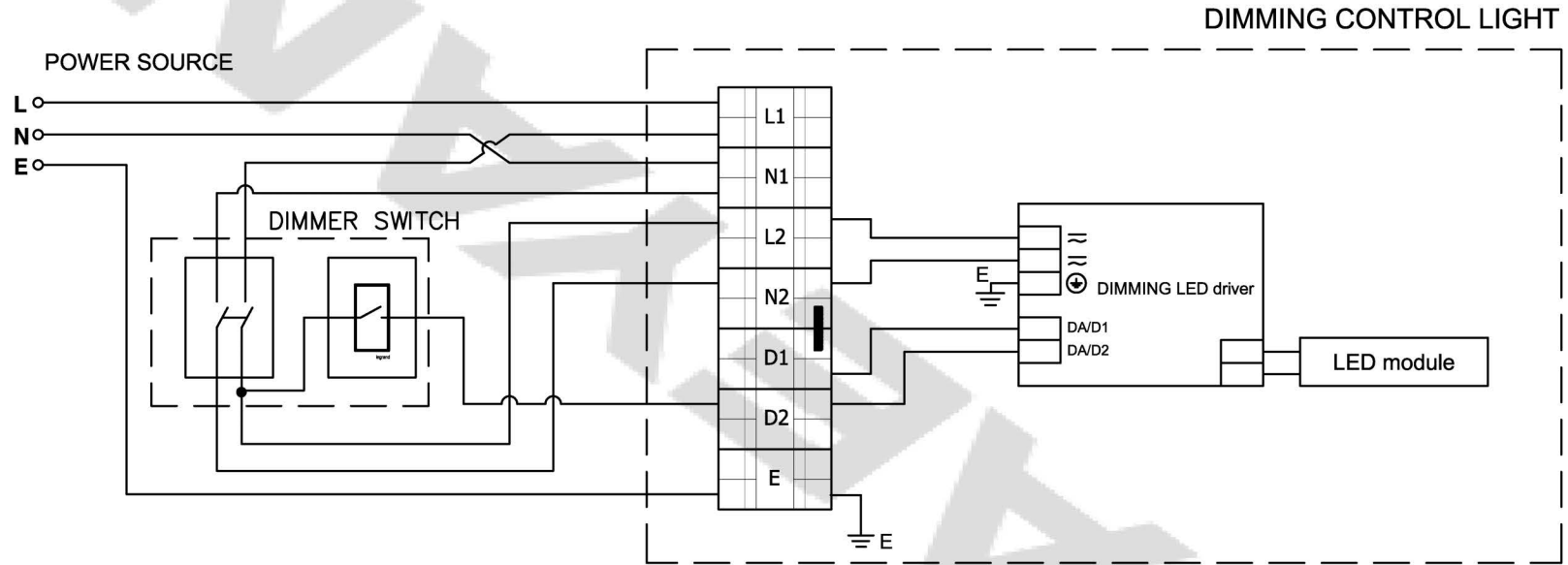

NO	CONTENT	DATE	REVISER	APPROVAL
△				
△				
△				



TITLE: LEB128WF-0550SNQC50D-A		SCALE	1/1	UNIT	MM	NO.	REVISED
		PROJECT METHOD		WEIGHT	KG	△	
		APPROVED	B. K. KIM			MATERIAL	ASS'Y
		CHECKED	W. J. JI			DWG NO.	
DATE	2015.12.04			SHEET NO.	16-A		